



Uniclass K41103:P7114	EPIC D11102:X724
CI/SfB (31.54)	Xn6

June 2000

## DIAMOND SLIMLINE PATIO [BEVELLED]

The classic bevelled lines and ride over technology ensure the Duraflex Patio Door is the professionals choice. 79mm from front to back this patio door will co-ordinate with both 65 and 70mm Diamond Suite allowing maximum choice for any job. A unique combination of design and value engineering that provides a cost-effective and secure solution to refurbishment or new build.



the natural choice

# specification

- Profile:
  - Diamond Slimline Patio [Bevelled]
- Colours:
  - White, Mahogany, Golden Oak,
  - Mahogany on White,
  - Golden Oak on White

- Profiles used:
  - 3600 Sash
  - 3601 Outerframe
  - 3605 Glazing Bead
  - 3603 Meeting Stile Cover
  - 3613 Steel Reinforcement
  - 3609 Weather Bar

- 3606 Midrail
- 3616 Low Threshold
- 3602 Threshold/Frame Cover
- 3611 Steel Reinforcement
- 3608 Meeting Claw
- 3610 3/4 Pane Adaptor

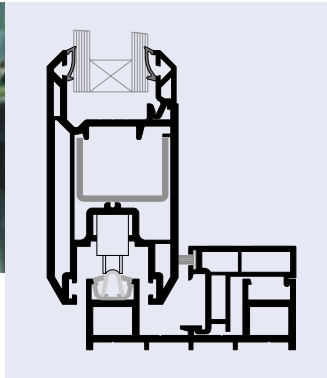

Cross section low threshold

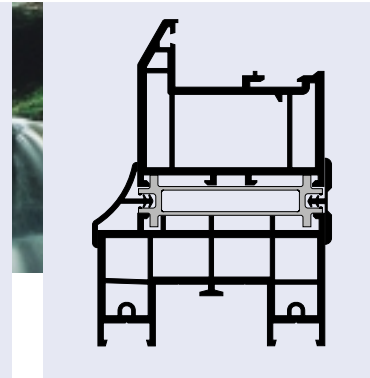

Patio to 65mm window joint

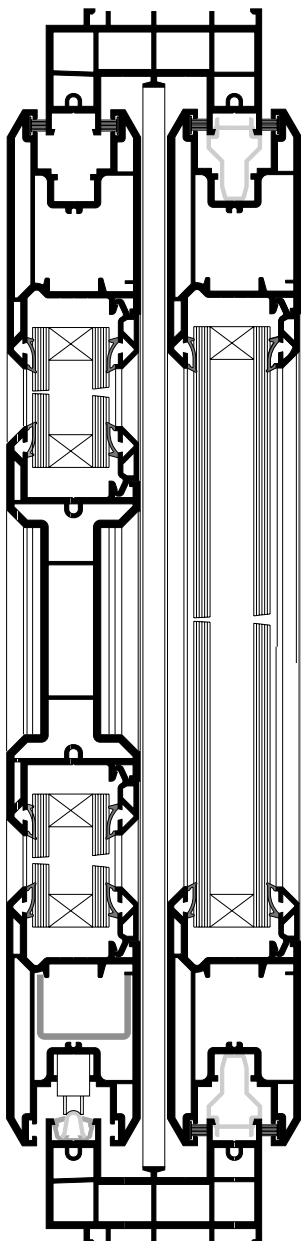
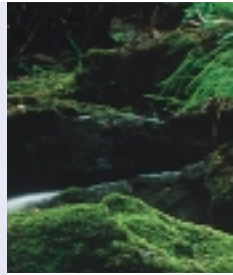

Cross section through horizontals

- New outerframe (79mm front to back dim<sup>n</sup>) can be fully welded or mechanically jointed.
- Threshold height of 58mm as standard or 39mm with low line.
- Dedicated frame couplers to suit 65mm and 70mm systems.
- New slim sash will incorporate low line post co-extruded gasket as standard (black).
- Glazing 28mm as standard.
- Easy to glaze, internally beaded system.
- Trickle ventilation provided through outerframe or over head vent.
- Midrail will accept any standard letter plate.
- 2, 3 and 4 pane options available as standard.
- Aluminium meeting claws provide optimum strength, covered by PVCu cover strips, prevent unsightly screw heads being seen through glass.



**DURAFLEX**  
MAKING THE DIFFERENCE

Customer Centre Central Way Arle Road Cheltenham Gloucestershire GL51 8LX  
Tel: 08705 351 351 [www.duraflex.co.uk](http://www.duraflex.co.uk)